

Алматы (7273)495-231
Ангарск (3955)60-70-56
Архангельск (8182)63-90-72
Астрахань (8512)99-46-04
Барнаул (3852)73-04-60
Белгород (4722)40-23-64
Благовещенск (4162)22-76-07
Брянск (4832)59-03-52
Владивосток (423)249-28-31
Владикавказ (8672)28-90-48
Владимир (4922) 49-43-18
Волгоград (844)278-03-48
Вологда (8172)26-41-59
Воронеж (473)204-51-73
Екатеринбург (343)384-55-89

Ижевск (3412)26-03-58
Иваново (4932)77-34-06
Иркутск (395)279-98-46
Казань (843)206-01-48
Калининград (4012)72-03-81
Калуга (4842)92-23-67
Кемерово (3842)65-04-62
Киров (8332)68-02-04
Коломна (4966)23-41-49
Кострома (4942)77-07-48
Краснодар (861)203-40-90
Красноярск (391)204-63-61
Курск (4712)77-13-04
Курган (3522)50-90-47
Липецк (4742)52-20-81

Магнитогорск (3519)55-03-13
Москва (495)268-04-70
Мурманск (8152)59-64-93
Набережные Челны (8552)20-53-41
Новокузнецк (3843)20-46-81
Ноябрьск (3496)41-32-12
Новосибирск (383)227-86-73
Омск (3812)21-46-40
Орел (4862)44-53-42
Оренбург (3532)37-68-04
Пенза (8412)22-31-16
Петрозаводск (8142)55-98-37
Псков (8112)59-10-37
Пермь (342)205-81-47

Ростов-на-Дону (863)308-18-15
Рязань (4912)46-61-64
Самара (846)206-03-16
Саранск (8342)22-96-24
Санкт-Петербург (812)309-46-40
Саратов (845)249-38-78
Севастополь (8692)22-31-93
Симферополь (3652)67-13-56
Смоленск (4812)29-41-54
Сочи (862)225-72-31
Ставрополь (8652)20-65-13
Сыктывкар (8212)25-95-17
Сургут (3462)77-98-35
Тамбов (4752)50-40-97
Тверь (4822)63-31-35

Тольяти (8482)63-91-07
Томск (3822)98-41-53
Тула (4872)33-79-87
Тюмень (3452)66-21-18
Улан-Удэ (3012)59-97-51
Ульяновск (8422)24-23-59
Уфа (347)229-48-12
Хабаровск (4212)92-98-04
Чебоксары (8352)28-53-07
Челябинск (351)202-03-61
Череповец (8202)49-02-64
Чита (3022)38-34-83
Якутск (4112)23-90-97
Ярославль (4852)69-52-93

Киргизия (996)312-96-26-47

Россия (495)268-04-70

Казахстан (772)734-952-31

<https://rotondi.nt-rt.ru> || rdy@nt-rt.ru



Прессы технология
глажки пиджаков
ЖЕНСКИХ



COMPUTERS ROTONDI

ROTONDI COMPUTERS

I nuovi computers, una rivoluzione tecnologica ROTONDI senza paragoni nel mercato internazionale.

Per poter stirare i tessuti di alta qualità e leggerezza o tecnologici disponibili oggi nel mercato mondiale, una macchina da stiro ad alta tecnologia deve essere dotata di un computer di controllo adeguato di pari qualità e capace di poter parzializzare micrometricamente ogni funzione di stiratura.

Come sempre ROTONDI all'avanguardia nello sviluppo tecnologico elettronico propone 3 tipi di computers.

LEONARDO EVOLUTION

Il massimo della tecnologia disponibile sul mercato internazionale, flessibilità e sofisticazione di programmazione unite ad una semplicità d'uso senza paragoni. Ideale per le aziende che desiderano un prodotto hi-tech senza compromessi.

Schermo LCD a colori da 10,4" con tecnologia Touch-Screen

Grazie allo schermo a colori il software è estremamente intuitivo, semplice e veloce sia da imparare che da utilizzare.

Memorizzazione infinita di programmi (più di 100.000) sia numerico che con nome alfanumerico

Programmazione fino a 15 funzioni di stiro per programma nella configurazione tandem, fino a 31 nella configurazione singola macchina

Base dei tempi selezionabile da 0,2 a 5 sec per passo

Funzione di copia programma all'interno del menu' di programmazione

Funzione Tool-Tip quindi tutte le funzioni di stiro visualizzate sullo schermo

Regolazione della pressione di stiro tramite valvola proporzionale con precisione 0,1 BAR – possibilità di avere pressioni diverse per ogni passo di programma.

Regolazione di 3 distanze di sfumatura per programma con precisione millimetrica

Possibilità di regolare in percentuale da 0 a 100% con steps di 1% quantità vapore superiore, aspirazione inferiore e soffiaggio (o in alternativa aspirazione superiore)

Porta USB per trasferimento programmi e parametri su altre macchine

Collegabile in rete via LAN a qualsiasi lap-top o pc con la possibilità di visualizzazione o di stampa del programma, nonché dei dati di produzione oraria/giornaliera /settimanale o mensile e controllo remoto macchina

Tramite porta usb possibilità di collegamento periferiche quali lettore di codice a barre per selezione automatica programma o stampante

Software sviluppato con sistema operativo WINDOWS XP EMBEDDED"

Intercambiabile con ogni programmatore ROTONDI di generazione precedente.

LEONARDO TOUCH SCREEN

La soluzione ideale per ogni tipo di azienda, il giusto compromesso tra costo e tecnologia. Flessibilità di programmazione, semplicità d'uso ed elevatissima affidabilità

Schermo LCD Touch Screen retroilluminato monocromatico blu di ampie dimensioni (6,4") con contrasto a regolazione automatica

Grazie alla tecnologia Touch-Screen, il software è estremamente intuitivo, semplice e veloce sia da imparare che da utilizzare.

Memorizzazione fino a 99 programmi sia numerico che con nome alfanumerico – Programmazione fino a 15 funzioni di stiro per programma nella configurazione tandem, fino a 31 nella configurazione singola macchina

Funzione di copia programma all'interno del menu' di programmazione

Funzione Tool-Tip quindi tutte le funzioni di stiro visualizzate sullo schermo

Regolazione della pressione di stiro infinita tramite valvola proporzionale con precisione 0,1 BAR – 3 pressioni per programma

Regolazione di 3 distanze di sfumatura per programma con precisione millimetrica

Porta RS232 per trasferimento programmi e parametri su altre macchine ROTONDI tramite apposita chiave di memoria. Porta IC2/CAN per il controllo remoto di altre schede ROTONDI.

Intercambiabile con ogni programmatore ROTONDI di generazione precedente

RAFFAELLO

Ideale grazie alla sua semplicità ed estrema economicità per le operazioni di stiro intermedio o per piccole produzioni.

Quattro display LED a 8 segmenti retroilluminati

Memorizzazione di 9 programmi in secondi

Programmazione di 5 funzioni di stiro, vapore superiore, aspirazione inferiore a piani chiusi, aspirazione inferiore a piani aperti, tempo di pressione e soffiaggio (o in alternativa secondo l'operazione vapore inferiore o aspirazione superiore)

The new computers mark a ROTONDI technological revolution that has no equal on the international market.

In order to iron light, top-quality fabrics, as well as the high-tech materials available on today's worldwide market, you need a hi-tech pressing machine equipped with a computer capable of performing at an equally high level of quality, controlling each pressing function with micrometric precision.

ROTONDI, always on the cutting edge of technological development proposes 3 different types of computers.

LEONARDO EVOLUTION

The most highly developed technology available on the international market: flexible, sophisticated programming combined with unsurpassed ease of use. Ideal for companies looking for an uncompromisingly hi-tech product.

A colour LCD screen measuring 10.4" and equipped with Touch-Screen technology.

Thanks to the colour screen, the software is extremely self-explanatory, simple and quick both to learn and use.

An endless capacity for memorising programs (more than 100,000), both digitally and with alphanumerical names

Programming of up to 15 pressing functions program in the tandem configuration, up to 31 in the single-machine configuration

Basic timing can be set at from 0.2 to 2.5 sec per passage step

Program copy function on programming menu

Tool-Tip function, meaning that all the functions are displayed on the screen

Adjustment of pressing pressure using a proportional valve with a precision of 0.1 BAR – possibility of setting different pressures for each passage of the program.

Possibility of adjusting 3 sponging/patting distances per program with millimetric precision

Possibility of adjusting from 0 to 100%, at intervals of 1%, the quantity of head steam, buck vacuum and blowing (or, as an alternative, head vacuum)

USB port for transferring programs and parameters into other ROTONDI machines

Connectable in network, via LAN, to any lap-top or pc, with the possibility of displaying or printing the program, as well as the hourly/daily/weekly or monthly production data, and remote control of machine

Using usb port, possibility of connection to peripherals, such as bar-code reader for automatic program selection or printer

Software developed with WINDOWS XP EMBEDDED" operating system Highly reliable

Interchangeable with any previous generation ROTONDI programmer.

LEONARDO TOUCH SCREEN

The ideal solution for any type of company, representing the perfect compromise between cost and technology. Programming flexibility, ease of use and high reliability

LCD back-lit monochromatic blue Touch Screen of large size (6.4"), with automatic contrast adjustment

Thanks to the touch-screen, the software is extremely self-explanatory, simple and quick both to learn and use.

Memorisation of up to 99 programs, both digital and with alphanumerical names

Programming of up to 15 pressing functions program in the tandem configuration, up to 31 in the single-machine configuration

Basic timing can be set at from 0.2 to 2.5 sec per passage step

Program copy function on programming menu

Tool-Tip function, meaning that all the functions are displayed on the screen

Infinite adjustment of pressing pressure using proportional valve with precision of 0.1 BAR – 3 pressures per program

Possibility of adjusting 3 sponging/patting distances per program with millimetric precision

RS232 port for transferring programs and parameters to other ROTONDI machines using a pen drive. IC2/CAN port for remote control of other ROTONDI boards.

Interchangeable with any previous generation ROTONDI programmer.

RAFFAELLO

Perfect for underpressing and small-scale operations, thanks to its simple, cost-saving design:

four LED displays made of 8 back-lit segments

memorisation of 9 programs in a matter of seconds

programming of 5 pressing functions, head steam, buck vacuum with head closed, buck vacuum with head open, timing of pressure and blowing (or, as an alternative, buck steam or head vacuum)



Computer Leonardo Evolution



Computer Leonardo Touch Screen



Computer Raffaello

STIRO FINALE - OFFPRESSING PLANCHADO FINAL

FRV 0-312DO

■ Macchina a scomparsa verticale per davanti. Forma doppia. con computer Leonardo e stiro di precisione. ■ Vertical full back press for L&R foreparts. Double buck. Equipped with Leonardo computer and precision pressing device. ■ Prensa con movimiento full back vertical para delanteros. Forma doble. Con programador Leonardo y dispositivo planchado de precision. ■ Doppelbügelpresse mit Leonardo - Steuerung und vertikalem „Full Back System“ für präzise Fertigbügeln von linken und rechten Jackett Vorderteilen. ■ Глаильный прусс с системой “Full Back” еля L&R полочук. С егойной формой. Комплектуется компьютером Leonardo и устройством пропуснодо еаглуния.

■ 完全后退式前(双模)压机,带直压装置、LEONARDO 数控电脑

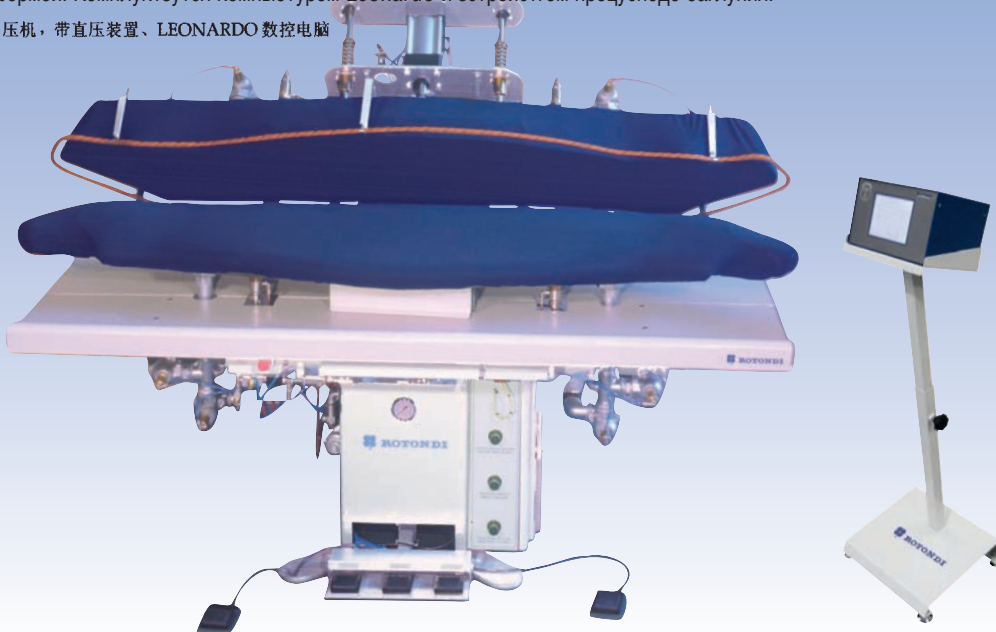

12RD 0-312

■ Carosello con rotazione 120 gradi per davanti con computer Leonardo e stiro di precisione. ■ 120 degree carousel for L&R forepart. Equipped with Leonardo computer and precision pressing device. ■ Carrusel con rotación de 120 grados para delanteros con programador Leonardo y dispositivo planchado de precision. ■ Karussell Bügelpresse mit 120° Rotation und Leonardo Computer für das präzise Fertigbügeln von linken und rechten Jackett Vorderteilen. ■ Карманный длаильный прусс с погоротом на 120° еля L&R полочки. Комплектуется компьютером Leonardo и устройством пропуснодо еаглуния.

■ 旋转式(180度)前身压机,带 LEONARDO 数控电脑

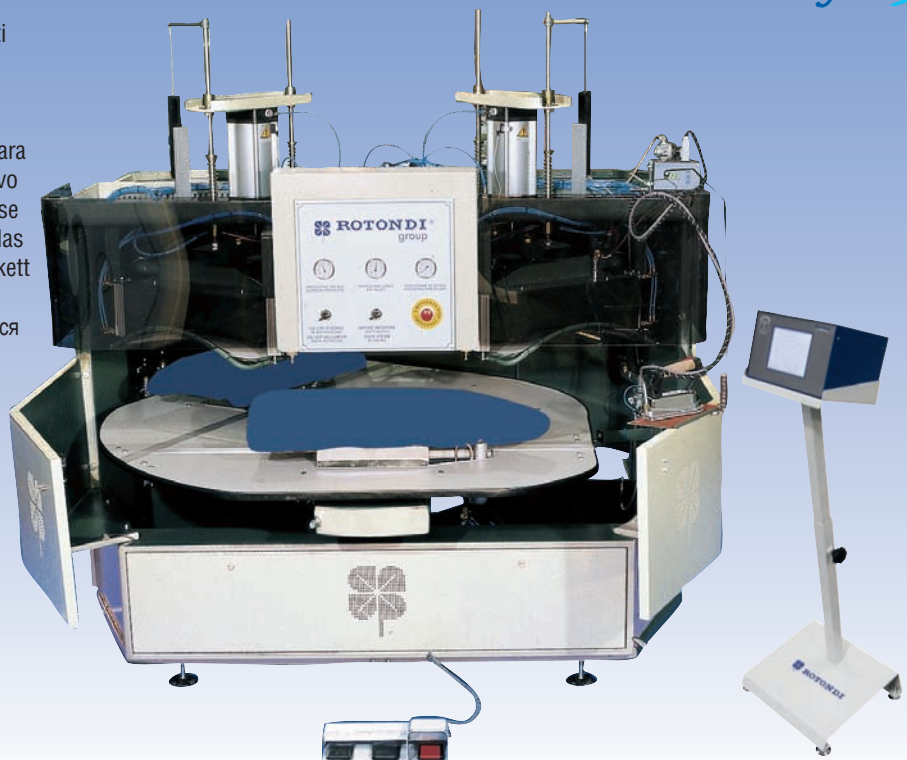

Tailoring Line



STIRO INTERMEDIO - UNDERPRESSING PLANCHADO INTERMEDIO

TAR U-162 + G-124

Tavolo per apertura cuciture fianchi, centro schiena e spalle. ■ Table for sides, centre back and shoulder seam opening. ■ Mesa para abrir costuras de costados, centro espalda y hombros. ■ Bügeltisch für das ergonomische Öffnen der Seitennähte, der Rückenmittelnäht sowie der Schulternähte. ■ Глаиельный стол еля боковых, заенудо цунтральнодо и плучугодо шга. ■ 后背缝、侧缝、肩缝、分缝烫台



TAR G-128

Tailoring Line

■ Tavolo per apertura cuciture spalle. ■ Table for shoulder seam opening. ■ Mesa para abrir costuras hombros. ■ Bügeltisch für das Ausbügeln der Schulternähte an Jacketts ■ Глаиельный стол еля раскалыгания плучугодо шга. ■ 肩缝、分缝烫台



TAR U-162

Tailoring Line

■ Tavolo per apertura cuciture fianchi e centro schiena. ■ Table for sides and centre back seam opening. ■ Mesa para abrir costura costados y centro espalda. ■ Bügeltisch für das ergonomische Öffnen der Seitennähte sowie der Rückenmittelnäht. ■ Глаиельный стол еля раскалыгания бокоогодо и заенудо цунтральнодо шгог. ■ 背缝、侧缝烫台



TAR SR-38 + 40

Tailoring Line

■ Tavolo per apertura cuciture bordi. ■ Table for edge seam opening. ■ Mesa para abrir costura cantos/bordes. ■ Spezialbügeltisch für das ergonomische Ausbügeln der Reverskanten, des Kragens sowie des Saumes. ■ Глаиельный стол еля раскалыгания шга борта пиежака. ■ 止口分缝烫台



STIRO INTERMEDIO - UNDERPRESSING PLANCHADO INTERMEDIO

TAR J-152 + 188

Tailoring Line

- Apertura cuciture interno manica e gomito.
- Sleeve hindarm and forearm seam opening.
- Bügeln der vorderen und hinteren Ärmelnaht.
- Abertura de costuras del interior de mangas y codos.
- Гладильный стол для открытия внутреннего и внешнего шва рукава.
- 甲外袖縫分縫燙台

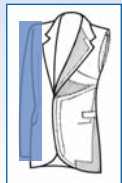

BL K-168

Tailoring Line

- Stiratura finale colli-giacche donna ■ Final ironing of collar-ladies jackets
- Planchado final de cuellos de mujer ■ Kragepresse
- Стол для окончательного подглаживания воротника дамских пальто

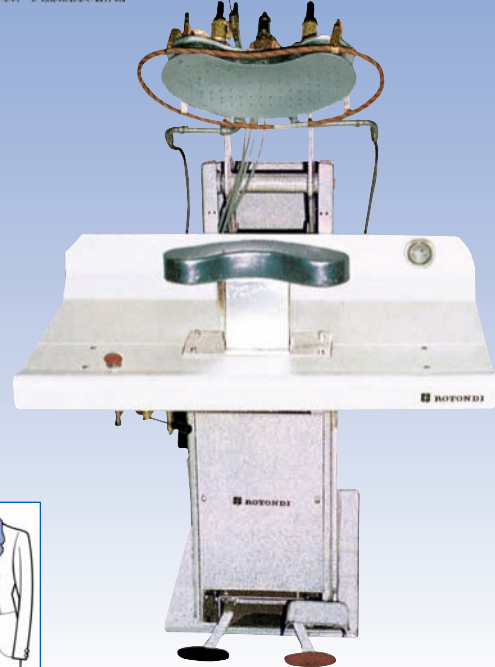

2004E

Tailoring Line

- Tavolo rettangolare, 130x65 cms, aspirante e soffiante con motore da 1 HP, regolabile in altezza. Forma riscaldata elettricamente o a freddo. Opzionale : LCD Computer RS-1 con inverter per regolazione quantita' aspirazione e soffiaggio.
- Rectangular flat table (130x65 cms) with vacuum and air-blowing with 1,0HP motor, height adjustable. Cold or electrically heated shape. Optional : Computer RS-1 with inverter control for vacuum and air-blowing qty adjustment.
- Rechteckiger Höhenverstellbarer Universalbügeltisch mit Vakuum und Blaseinrichtung mit 1,0 PS Leistung. Wahlweise mit elektrisch beheizter oder kalter Arbeitsfläche (130cm * 65cm). Optional: LCD Computer RS-1 zur Steuerung des Vakuums und der Blaseinrichtung.
- Mesa rectangular 130x65 cms aspirante y soplante con motor de 1 HP regulable en altura. Plato con calefaccion electrica o en frio. Opcional: LCD computer RS-1 con invertidor de frecuencia para regulacion de la cantidad de aspiracion y soplado
- Прямоугольный гладильный стол (130x65 см) с вакуумом и поддувом мотор 1 л.с., высота стола регулируется. Подогрев стола электричеством/без подогрева. Дополнительные опции: Computer RS-1 для регулировки кол-ва вакуума и поддува.

- 多功能燙台
平燙台130X65CM, 帶自吹吸風馬達功率1.0HP, 高度可調, 模具加溫裝
選購裝置: RS-1控制電腦。



COLOMBO



STIRO FINALE - OFFPRESSING PLANCHADO FINAL

12RD OU-312/315

■ Carosello con rotazione 120 gradi per davanti e schiene con computer Leonardo e stiro di precisione. ■ 120 degree carousel for L&R forepart and sides and back. Double bucks. Equipped with Leonardo computer and precision pressing device. ■ Carrusel con rotación de 120 grados para delanteros y espaldas – formas dobles – con programador Leonardo y dispositivo planchado de precisión. ■ Bügelpresse mit 120° Rotation, Leonardo Computersteuerung und Präzisionspresseinrichtung für das präzise Fertigbügeln von linken und rechten Jackett Vorder- und Rückenteilen. ■ Карманный длаеильный прусс с погоротом на 120° еля пелочки, бокогинок и спинки. С егоиной формой. Комплуктсутся компьютером Leonardo и стройством процуснодо еаглуния
 ■ 旋转式(120度)前身、后背压机, 带 LEONARDO 数控电脑

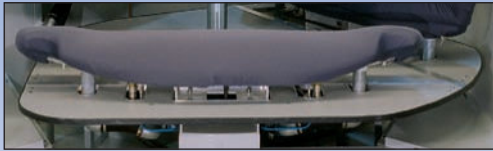

FRV 0-312

■ Macchine a scomparsa verticale per davanti con computer Leonardo e stiro di precisione. ■ Vertical full back presses for L&R foreparts. Equipped with Leonardo computer and precision pressing device. ■ Prensa con movimiento full back vertical para delanteros con programador Leonardo y dispositivo planchado de precisión. ■ Bügelpresse mit Leonardo - Steuerung und vertikalem „Full Back System“ für präzise Fertigbügeln von linken und rechten Jackett Vorderteilen
 ■ Глаеильный прусс с систумой “Full Back” еля L&R полочки. Комплуктсутся компьютером Leonardo и стройством процуснодо еаглуния. ■ 完全后退式前身(单模)压机, 带直压装置, LEONARDO 数控电脑

Tailoring Line

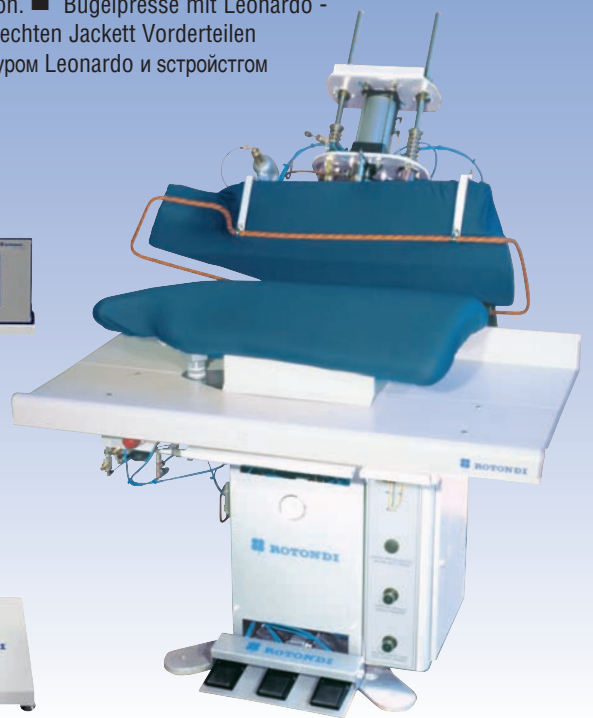
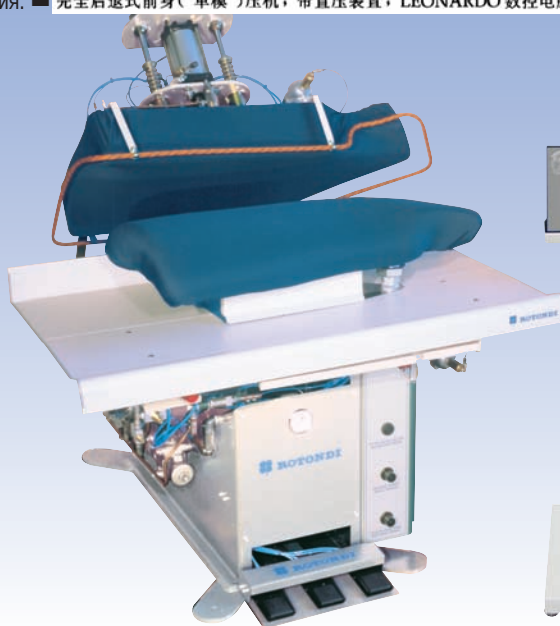

STIRO FINALE - OFFPRESSING PLANCHADO FINAL

18RD 0-312

■ Carosello con rotazione 180 gradi per davanti con computer Leonardo e stiro di precisione. ■ 180 degree carousel for L&R forepart. Equipped with Leonardo computer and precision pressing device. ■ Carrusel con rotación de 180 grados para delanteros con programador Leonardo y dispositivo planchado de precisión. ■ Karussell Bügelpresse mit 180° Rotation und Leonardo Computer für das präzise Fertigbügeln von linken und rechten Jackett Vorderteilen. ■ Карманный для ивильный прусс с поворотом на 180° еля L&R полочки. Комплектуется компьютером Leonardo и сстройством проуснодо еаглуния. ■ 旋转式(180度)前身压机, 带 LEONARDO 数控电脑



FRV U-315

Tailoring Line

■ Macchine a scomparsa verticali per schiene con computer Leonardo e stiro di precisione. ■ Vertical full back presses for L&R sides and back. Equipped with Leonardo computer and precision pressing device. ■ Prensas con movimiento full back vertical para espaldas con programador Leonardo y dispositivo planchado de precisión. ■ Bügelpresse mit vertikalen „Full Back System“ und Leonardo Computersteuerung für das präzise Fertigbügeln des linken und rechten Rückenteils. ■ Глаеильный прусс с систумой “Full Back” еля L&R бокогинок и спинки. Комплектуется компьютером Leonardo и сстройством проуснодо еаглуния. ■ 完全后退式后背(单模)压机, 带直压装置、LEONARDO 数控电脑



STIRO FINALE - OFFPRESSING PLANCHADO FINAL

FRV U-315DO

■ Macchina a scomparsa verticale per schiene – forma doppia – con computer Leonardo e stiro di precisione. ■ Vertical full back press for L&R sides and back – double buck. Equipped with Leonardo computer and precision pressing device. ■ Prensa con movimiento full back vertical para espaldas – forma doble - con programador Leonardo y dispositivo planchado de precision. ■ Doppelbügelpresse mit vertikalen „Full Back System“ und Leonardo Computersteuerung für das präzise Fertigbügeln des linken und rechten Rückenteils ■ Глаеильный прусс с систумой “Full Back” еля L&R бокогинок и спинки. С егойной формой. Комплектуется компьютером Leonardo и стройством процуснодо еаглуния.

■ 完全后退式后背(双模)压机, 带直压装置、LEONARDO 数控电脑

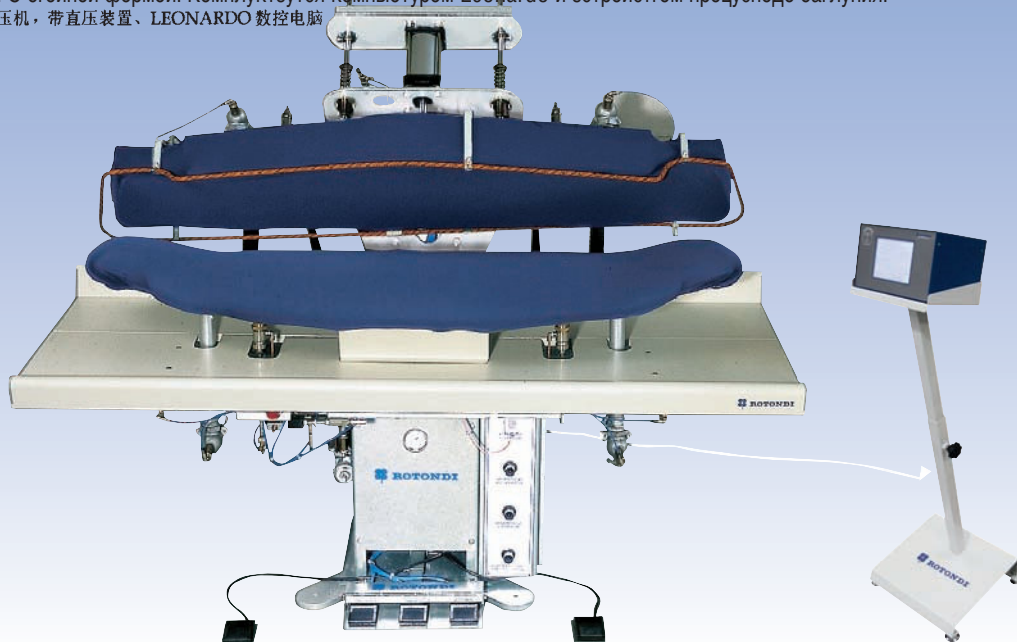

12RD U-315

Tailoring Line

■ Carosello con rotazione 120 gradi per schiene con computer Leonardo e stiro di precisione. ■ 120 degree carousel for L&R sides and back. Equipped with Leonardo computer and precision pressing device. ■ Carrusel con rotacion de 120 grados para espaldas con programador Leonardo y dispositivo planchado de precision. ■ Karussell Bügelpresse mit 120° Rotation und Leonardo Computersteuerung für das präzise Fertigbügeln des linken und rechten Rückenteils. ■ ?Карсульный длаеильный прусс с погоротом на 120° еля L&R бокогинок и спинки. Комплектуется компьютером Leonardo и стройством процуснодо еаглуния. ■ 旋转式(180度)后背压机, 带 LEONARDO 数控电脑

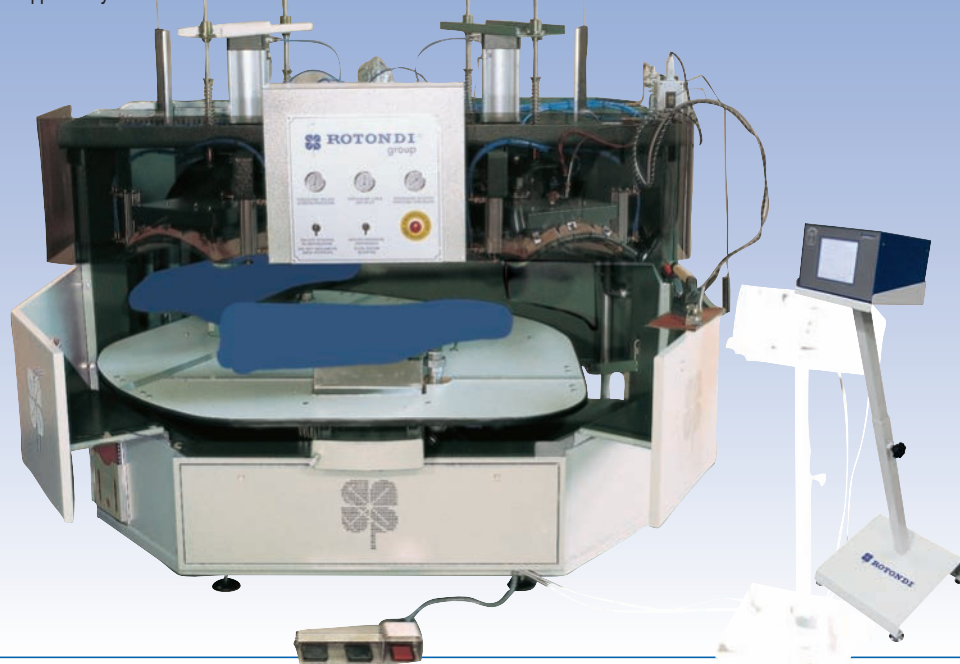

STIRO FINALE - OFFPRESSING PLANCHADO FINAL

18RD U-315D0

■ Carosello con rotazione 180 gradi per schiene con computer Leonardo e stiro di precisione. ■ 180 degree carousel for L&R sides and back. Equipped with Leonardo computer and precision pressing device. ■ Carrusel con rotación de 180 grados para espaldas con programador Leonardo y dispositivo planchado de precisión. ■ Karussell Bügelpresse mit 180° Rotation und Leonardo Computersteuerung für das präzise Fertigbügeln des linken und rechten Rückenteils. ■ Карсультный для аеильный прусс с погоротом на 180° еля L&R бокогинок и спинки. Комплуктсутся компьютером Leonardo и стройством процеснодо еаглуния. ■ 旋转式(180度)后背压机, 带 LEONARDO 数控电脑

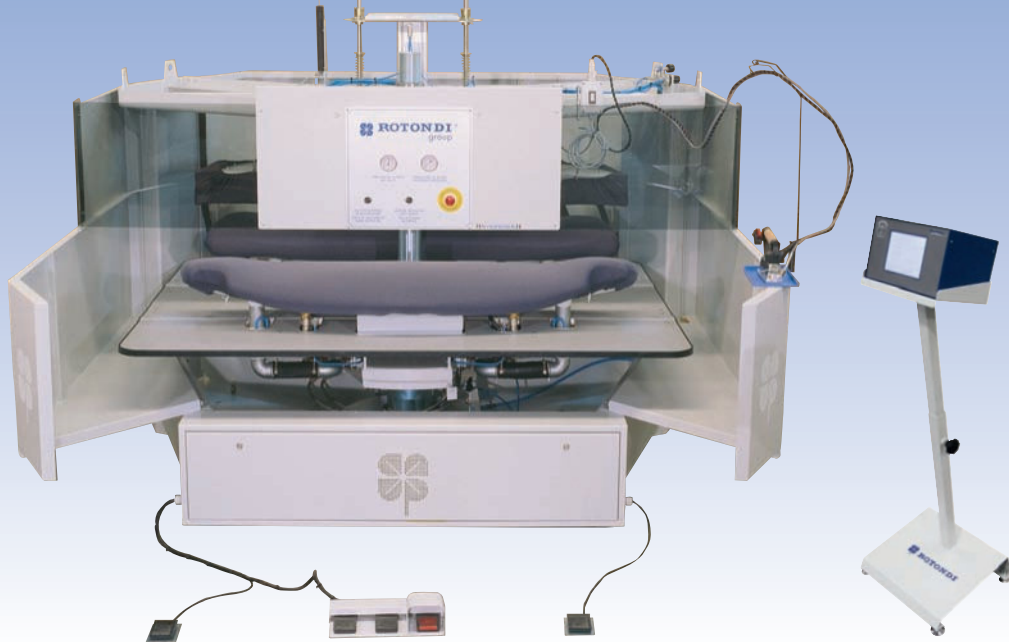

BL K-132

■ Stiro colli e revers rullati giacche da donna ■ Collar and rolled lapel offpressing-ladies jackets
■ Planchado cuello y solapa-chaquetas de mujer ■ Kragen und Revers Fertigbügeln
■ Пресс для прессования воротника и закругления лацкана. ■ 女装翻领头机。

Tailoring Line

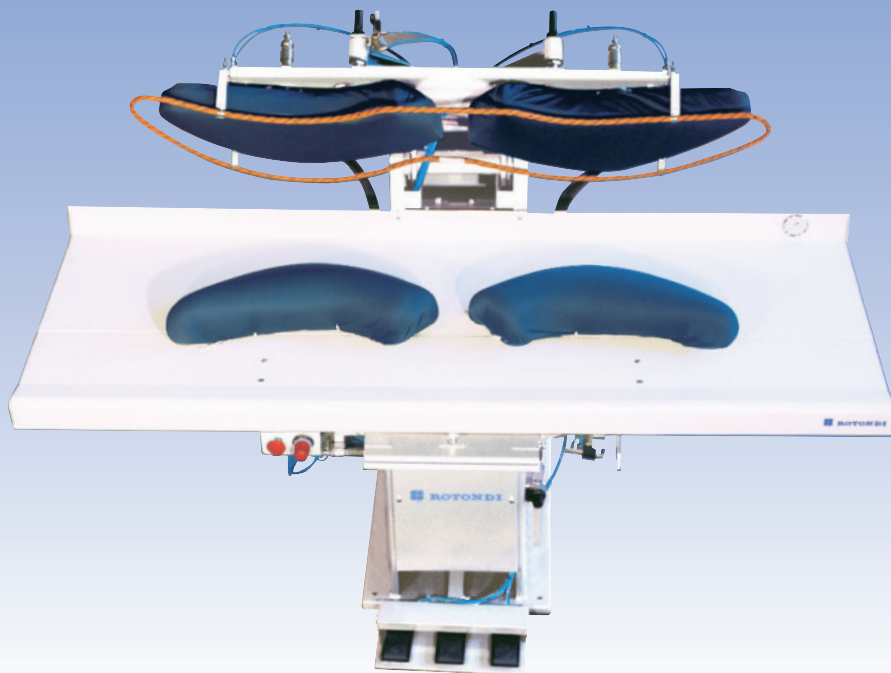

STIRO FINALE - OFFPRESSING PLANCHADO FINAL

Tailoring Line

GV-288

■ Macchina a discesa verticale indipendente per spalle con computer Leonardo e dispositivo stiro di precisione. ■ Vertical press for L&R shoulder. Equipped with Leonardo computer and precision pressing device. ■ Prensa vertical para hombros con programador Leonardo y dispositivo planchado de precision. ■ Automatische Vertikalpresse mit Leonardo Steuerung für das präzise Fertigbügeln der L & R Schulterpartie ■ Вуртикальньй длаеильньй прусс еля L&R плуча. Комплектуется компьютером Leonardo и сстройством проусснодо еаглуния. ■ 双肩定型压机，带 LEONARDO 数控电脑



FORME INTERCAMBIABILI
INTERCHANGEABLE HEADS AND BUCKS



SPL



STIRO FINALE - OFFPRESSING PLANCHADO FINAL

GJ-328

■ Unita' automatica per spalle, giri e maniche con computer Leonardo e stiro di precisione. ■ Automatic unit for L&R shoulder, sleeve and arm-hole creasing. Equipped with Leonardo computer and precision pressing device. ■ Unidad automatica para planchar hombros, sisa y manga con programador Leonardo y dispositivo planchado de precision. ■ Automatische Vertikalbügelpresse mit Leonardo Computersteuerung sowie Präzisionspresseinrichtung für das Fertigbügeln der L & R Schulter, des L & R Ärmels sowie des L & R Armloches ■ Автоматическую сстройсто еля L&R плеча, рскара и рскарной оймы. ■ 自动肩袖一体定型压机，带 LEONARDO 数控电脑



1



2



BL G-101/S

■ Chiusura giri. ■ Arm-hole creasing. ■ Cerras sisa. ■ Bügelpresse zum Bügeln des Armlochs ■ Глаеильный прусс еля рскара. ■ 袖垄定型压机



G-101/S



STIRO FINALE - OFFPRESSING PLANCHADO FINAL

BL J-1/S

■ Bloccaggio manica. ■ Sleeve blocking / draping. ■ Bloquear manga.
■ Bügelpresse zum Drapieren des Ärmels ■ Глаеильный прусс еля
отеулки рскара. ■ 袖山定型压机

Tailoring Line



BLV 7030

■ Macchina verticale per stiro manica. ■ Vertical scissor press
for sleeve pressing. ■ Prensa vertical para mangas. ■ Vertikale
Bügelpresse für das Bügeln des L & R Ärmels ■ Глаеильный
прусс еля отеулки рскара ■ 下袖拍烫压机

Tailoring Line

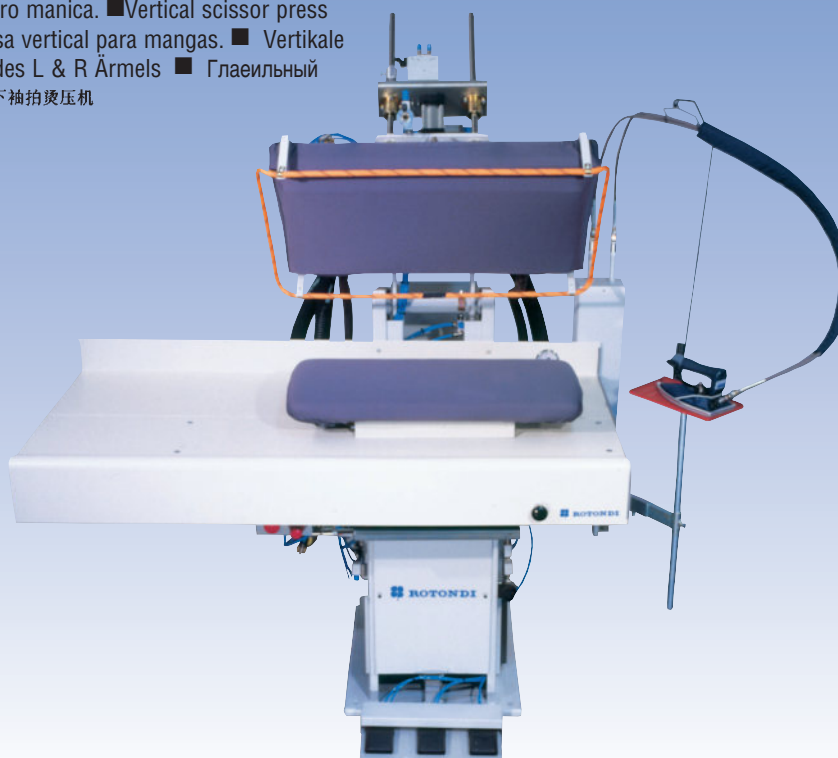

STIRO FINALE - OFFPRESSING PLANCHADO FINAL

TAR FL-115

Tailoring Line

■ Tavolo aspirante e soffiante per fodere e ritocco finale. ■ Vacuum and air-blowing table for lining smoothing and touch-up. ■ Mesa aspirante y soplante para retoque final y forros. ■ Spezialbügeltisch mit integrierter Vakuump- und Blaseinrichtung für das Glätten des Futters sowie Finish Bügelarbeiten. ■ Глаеильный стол с гакссмом и поесгом еля гырагнигания поеклаеки и отеулки ■ 衬里吹吸风修烫台



TAR FL-4

Tailoring Line

■ Tavolo aspirante e soffiante per fodere e ritocco finale. ■ Vacuum and air-blowing table for lining smoothing and touch-up. ■ Mesa aspirante y soplante para retoque final y forros. ■ Spezialbügeltisch mit integrierter Vakuump- und Blaseinrichtung für das Glätten des Futters sowie Finish Bügelarbeiten. ■ Глаеильный стол с гакссмом и поесгом еля гырагнигания поеклаеки и отеулки. ■ 后整理衬里吹吸风修烫台



TAR FL-90

Tailoring Line

■ Tavolo aspirante e soffiante per fodere e ritocco finale. ■ Vacuum and air-blowing table for lining smoothing and touch-up. ■ Mesa aspirante y soplante para retoque final y forros. ■ Spezialbügeltisch mit integrierter Vakuump- und Blaseinrichtung für das Glätten des Futters sowie Finish Bügelarbeiten. ■ Глаеильный стол с гакссмом и поесгом еля гырагнигания поеклаеки и отеулки. ■ 后整理吹吸风烫台



STIRO FINALE - OFFPRESSING PLANCHADO FINAL

BL CO-90/AUT

- Universale con caldaia e aspiratore incorporati (lungh. 117 cms)
Caldaia con capacita' 24 litri - 12 o 15 KW e aspiratore 0,75HP
- Steam and vacuum self-contained general utility press (117 cms long). Electric steam boiler 24 litres - 12 or 15 kW and vacuum unit 0,75HP.
- Universalbügelpresse mit 117 cm Länge, einem integrierten 24 Liter Dampferzeuger, wahlweise mit 12KW oder 15KW, sowie einer Vakuumeinheit mit 0,75 PS Leistung.
- Prensa universal con generador de vapor electrico y aspirado incorporados (Largo plato 117 cms). Caldera con capacidad de 24 litros - 12 o 15 KW - aspirador 0,75HP
- Универсальный гладильный пресс(длина 117 см)
- 万用压机带自吸风马达功率0.75HP, 配24升电锅炉功率12-15KW。

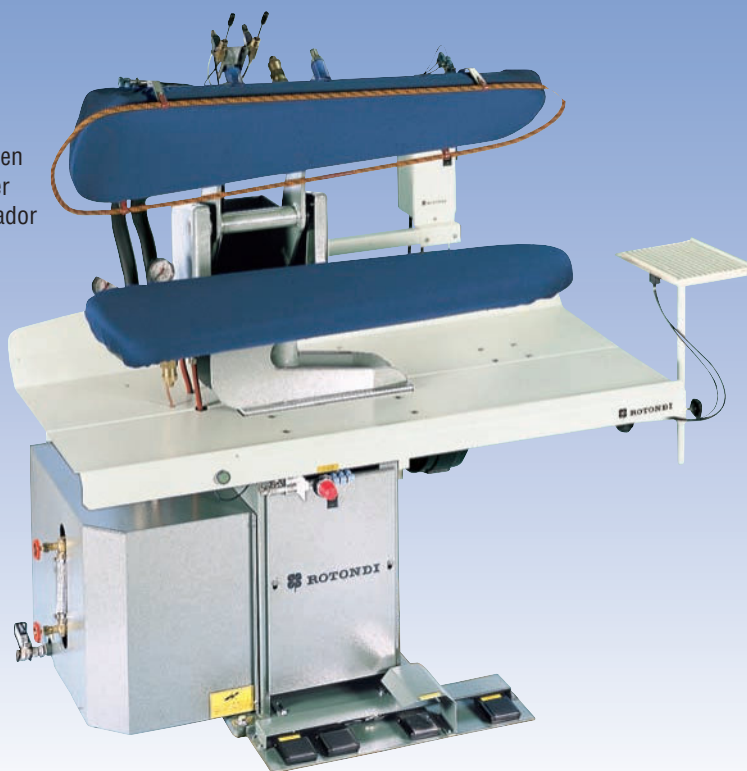

BL CO-90/BL CO-49

- General utility press (CO-90 – 117 cms long – CO-49 – 124 cms long)
- Universale (CO-90 – lungh. 117 cm – CO-49 – 124 cm)
- Universalbügelpresse für Zwischen- und Fertigbügelarbeiten. (CO – 90 mit 117cm und CO-49 mit 124cm Länge)
- Prensa universal (CO-90 Largo 117 cms – CO-49 – Largo 124 cms)
- Универсальный гладильный пресс(длина 117 см) со встроенным парогенератором(емкость 24 л., 12-15 кВт., вакуум 0,75 л.с.).
- 万用压机

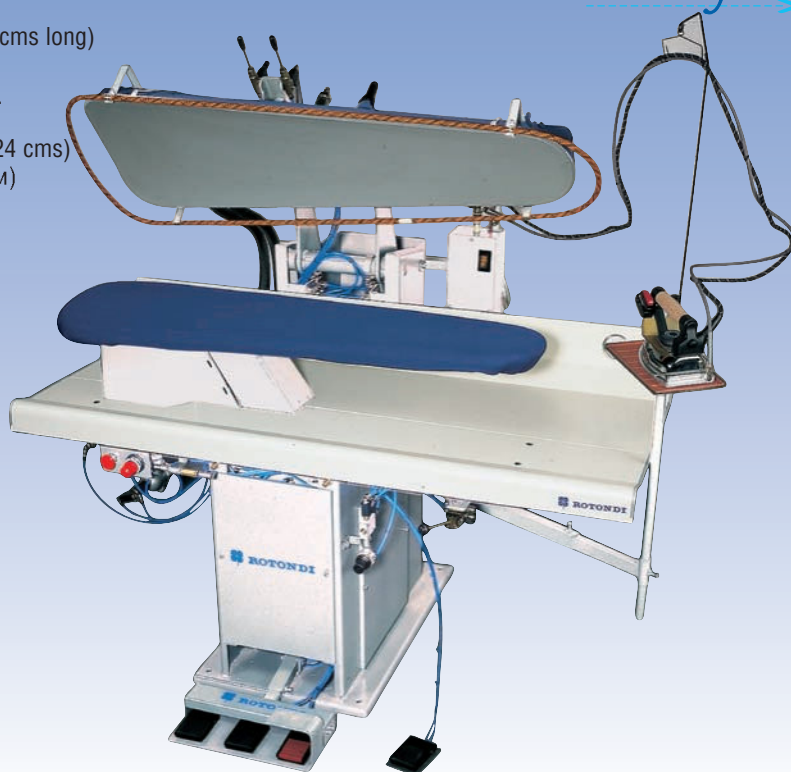

STIRO FINALE - OFFPRESSING PLANCHADO FINAL

2060

■ Manichino automatico, per stiro giacche e cappotti donna o uomo o capi in maglieria, di dimensioni estremamente compatte. ■ Automated form finisher for ironing men's or women's jackets and overcoats, or wool garments, extremely compact in size. ■ Automatische Bügelpuppe zum Bügeln von Strickware, Jacken und Mänteln. Unser besonderes Augenmerk galt der Wirtschaftlichkeit und der kompakten Bauform.

■ Maniquí automático de dimensiones extremadamente compactas para planchado de chaquetas y abrigos de hombre y mujer, o prendas en tejido de punto.

■ Очень компактный автомат-манекен для утюжки женских/мужских пиджаков и пальто или 1 женских/мужских пиджаков и пальто или трикотажных изделий.



Tailoring Line

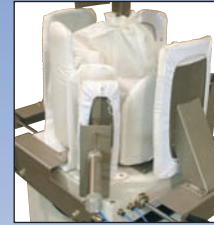

SERIES 2000E

■ Tavolo universale aspirante e soffiante con motore da 1 HP, regolabile in altezza. Forma riscaldata elettricamente o a freddo. Opzionale : LCD Computer RS-1 con inverter per regolazione quantità' aspirazione e soffiaggio. ■ Utility table with vacuum and air-blowing with 1,0HP motor, height adjustable. Cold or electrically heated shape.

Optional : LCD Computer RS-1 with inverter control for vacuum and air-blowing qty. adjustment.

■ Höhenverstellbarer Universalbügeltisch mit Vakuum und Blaseinrichtung mit 1,0 PS Leistung. Wahlweise mit elektrisch beheizter oder kalter Arbeitsfläche. Optional: LCD Computer RS-1 zur Steuerung des Vakuums und der Blaseinrichtung.

■ Mesa universal aspirante y soplante con motor de 1 HP, regulable en altura. Plato con calefaccion electrica o en frio. Opcional : LCD computer RS-1 con inverter de frecuencia para regulacion de la cantidad de aspiracion y soplado

■ Универсальный гладильный стол с вакуумом и и поддувом мотор 1 л.с., высота стола регулируется. Подогрев стола электричеством/без подогрева. Дополнительные опции: Computer RS-1 для регулировки кол-ва вакуума и поддува.

■ 电脑控制多功能女装专用烫台，带吹吸风装置，马达功率1.0 HP，模具高度可调，带加热装置。选购装置：RS-1控制电脑。



Tailoring Line



TECHNICAL DATA

TAR

	aspirazione: vacuum: aspiración:	autonoma self-contained con motor	centralizzata central vacuum sin motor
Voltaggio • Voltage • Voltaje • Spannung Ein- oder Dreiphasig • ?-??-??-??-??-??	V	220-400/3/50-60	-
Voltaggio ferro • Iron voltage • Voltaje de la plancha • Spannung Bügeleisen • ?-??-??-??-??-??	V	230/1/50-60	230/1/50-60
Potenza totale • Total power • Potencia total • Leistung • ?-??-??-??-??-??	W	1600	1000
Entrata aspirazione • Air inlet • Entrada aire • Luftanschluss • ?-??-??-??-??-??		-	1 1/4" or 2"
Entrata aria • Air inlet • Entrada aire • Luftanschluss • ?-??-??-??-??-??	mm	4	4
Pressione aria • Air pressure • Presión aire • Arbeitsdruck (Luft) • ?-??-??-??-??-??	BAR (psi)	5 (75)	5 (75)
Entrata vapore • Steam inlet • Entrada de vapor • Dampfanschluss • ?-??-??-??-??-??		3/8"	3/8"
Scarico condense • Condensate return • Retorno condensaciones • Kondenswasserrücklauf • ?-??-??-??-??-??		3/8"	3/8"
Pressione vapore • Steam pressure • Presión de vapor • Arbeitsdruck (Dampf) • ?-??-??-??-??-??	BAR (psi)	4,5 (65)	4,5 (65)

BL - FR - FRV

12RD - 18RD

Voltaggio • Voltage • Voltaje • Spannung Ein – oder Dreiphasig • ?-??-??-??-??-??	V	230/1/50-60	230/1/50-60
Entrata vapore • Steam inlet • Entrada de vapor • Dampfanschluss • ?-??-??-??-??-??		1/2"	1/2"
Pressione vapore • Steam pressure • Presión de vapor • Arbeitsdruck (Dampf) • ?-??-??-??-??-??	BAR (psi)	5 (70)	5 (70)
Ritorno condense • Condensate return • Retorno condensaciones • Kondenswasserrücklauf • ?-??-??-??-??-??		1/2"	1/2"
Entrata aspirazione • Air inlet • Entrada aire • Luftanschluss • ?-??-??-??-??-??		1 1/4" or 2"	3"
Entrata aria • Air inlet • Entrada aire • Luftanschluss • ?-??-??-??-??-??		3/8"	3/8"
Pressione aria • Air pressure • Presión aire • Arbeitsdruck (Luft) • ?-??-??-??-??-??	BAR (psi)	7(100)	7 (100)

GJ

GV

Voltaggio • Voltage • Voltaje • Spannung Ein- oder Dreiphasig • ?-??-??-??-??-??	V	230/1/50-60	230/1/50-60
Entrata vapore • Steam inlet • Entrada de vapor • Dampfanschluss • ?-??-??-??-??-??		2x1 /2"	2X1/2"
Pressione aria • Air pressure • Presión aire • Arbeitsdruck (Luft) (Dampf) • ?-??-??-??-??-??	BAR (psi)	5 (70)	5 (70)
Ritorno condense • Condensate return • Retorno condensaciones • Kondenswasserrücklauf • ?-??-??-??-??-??		4x1/2"	2x1/2"
Entrata aspirazione • Air inlet • Entrada aire • Luftanschluss • ?-??-??-??-??-??		2x2"	2x1 1/4"
Entrata aria • Air inlet • Entrada aire • Luftanschluss • ?-??-??-??-??-??		3/8"	3/8"
Pressione vapore • Steam pressure • Presión vapor • Arbeitsdruck • ?-??-??-??-??-??	BAR (psi)	7 (100)	7 (100)

SERIE TAR: STIRO FINALE GIACCA - SERIES TAR: JACKETS OFFPRESSING - SERIES TAR: PLANCHADO FINAL CHAQUETAS - Ø 110 (MM)

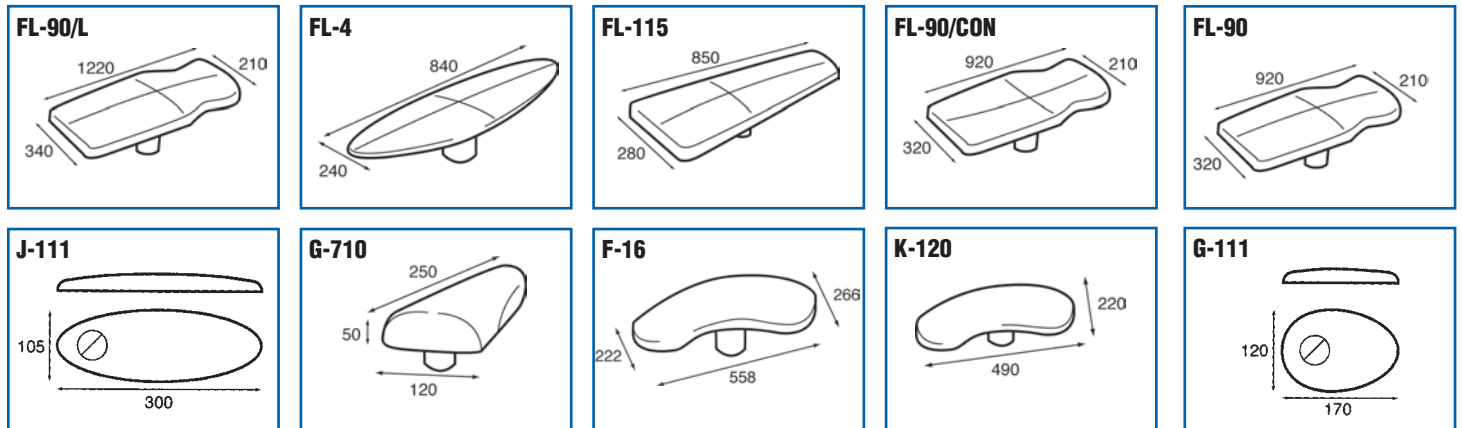

SERIE TAR: STIRO INTERMEDIO GIACCA - SERIES TAR: JACKETS UNDERPRESSING - SERIES TAR: PLANCHADO INTERMEDIO CHAQUETAS Ø 110 (MM)

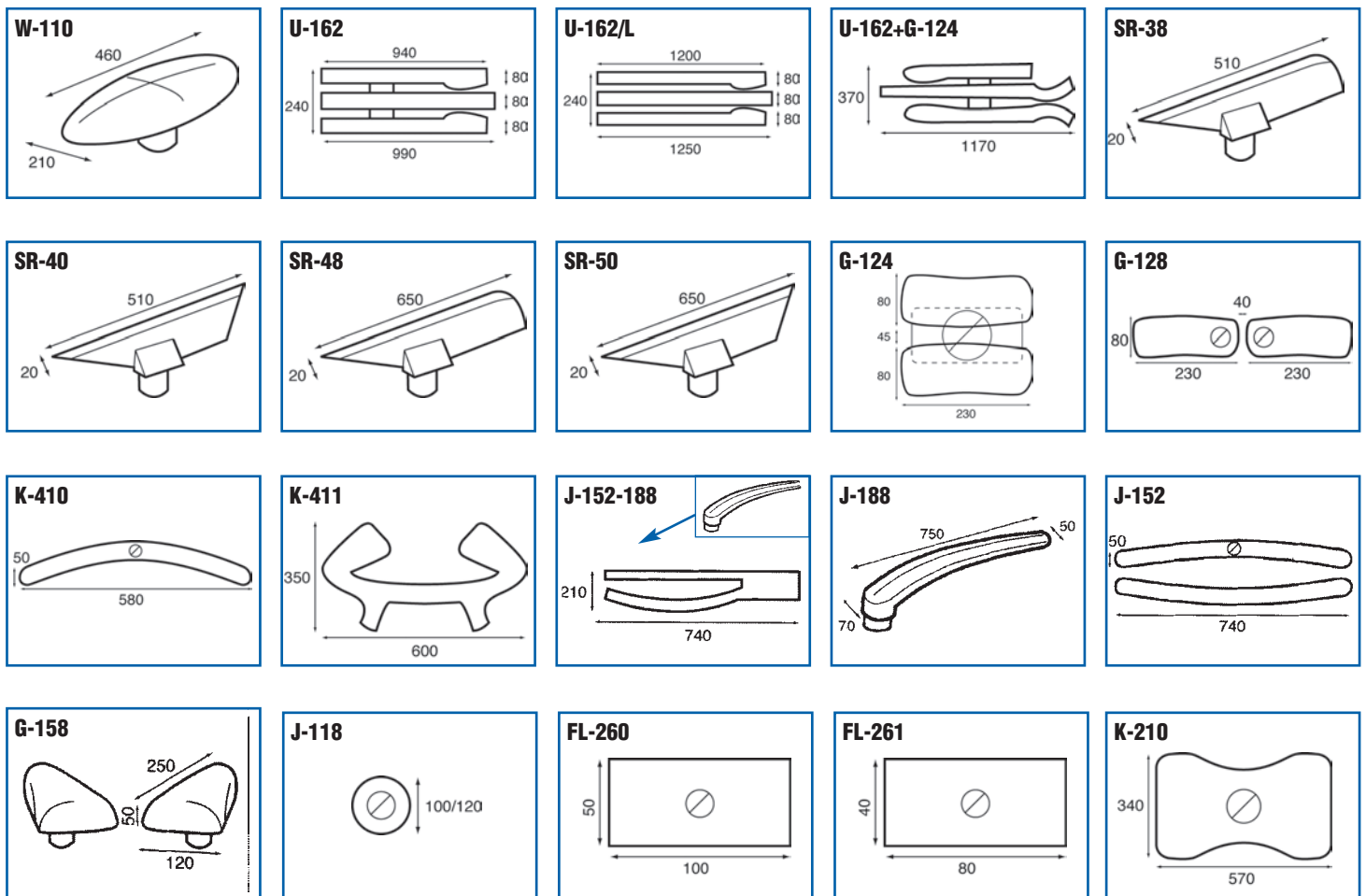

Forma principale tavoli (mm) - Main buck tables (mm) - Platos principales mesas (mm) - Formen für Bügeflächen (mm) - Plateau principales tables (mm)

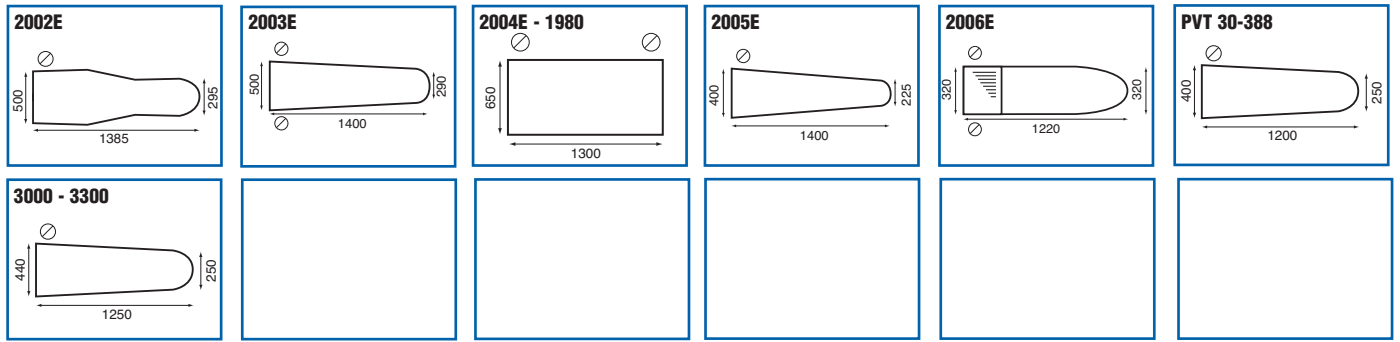

Forme per bracci (mm) - Swing arm bucks (mm) - Formas para brazos moviles (mm) - Formen für Schwenkarme (mm) - Janettes (mm) ø 85 mm

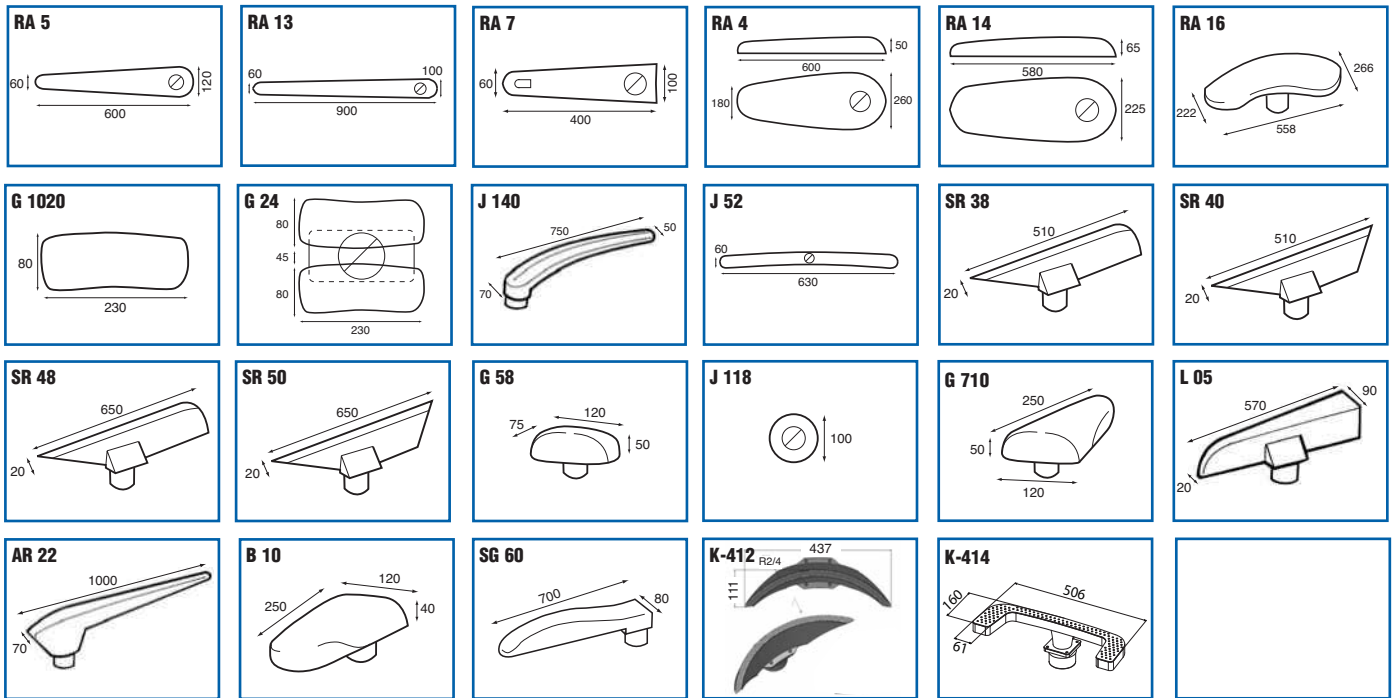

Forme per presse (mm) - Presses bucks (mm) - Platos prensas (mm) - Formen für Bügelpressen (mm) - Plateau pour presses (mm)

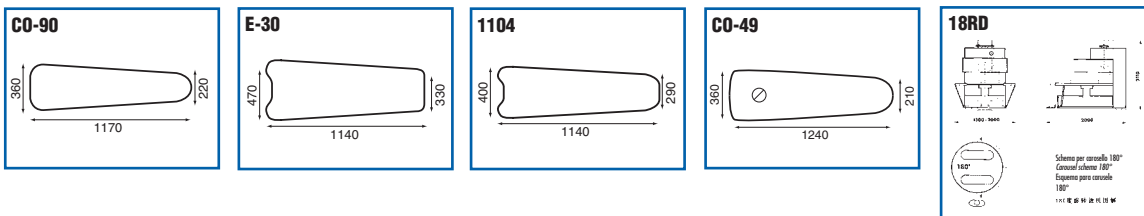

Алматы (7273)495-231
 Ангарск (3955)60-70-56
 Архангельск (8182)63-90-72
 Астрахань (8512)99-46-04
 Барнаул (3852)73-04-60
 Белгород (4722)40-23-64
 Благовещенск (4162)22-76-07
 Брянск (4832)59-03-52
 Владивосток (423)249-28-31
 Владикавказ (8672)28-90-48
 Владимир (4922) 49-43-18
 Волгоград (844)278-03-48
 Вологда (8172)26-41-59
 Воронеж (473)204-51-73
 Екатеринбург (343)384-55-89

Ижевск (3412)26-03-58
 Иваново (4932)77-34-06
 Иркутск (395)279-98-46
 Казань (843)206-01-48
 Калининград (4012)72-03-81
 Калуга (4842)92-23-67
 Кемерово (3842)65-04-62
 Киров (8332)68-02-04
 Коломна (4966)23-41-49
 Кострома (4942)77-07-48
 Краснодар (861)203-40-90
 Красноярск (391)204-63-61
 Курск (4712)77-13-04
 Курган (3522)50-90-47
 Липецк (4742)52-20-81

Магнитогорск (3519)55-03-13
 Москва (495)268-04-70
 Мурманск (8152)59-64-93
 Набережные Челны (8552)20-53-41
 Нижний Новгород (831)429-08-12
 Новокузнецк (3843)20-46-81
 Ноябрьск (3496)41-32-12
 Новосибирск (383)227-86-73
 Омск (3812)21-46-40
 Орел (4862)44-53-42
 Оренбург (3532)37-68-04
 Пенза (8412)22-31-16
 Петрозаводск (8142)55-98-37
 Псков (8112)59-10-37
 Пермь (342)205-81-47

Ростов-на-Дону (863)308-18-15
 Рязань (4912)46-61-64
 Самара (846)206-03-16
 Саранск (8342)22-96-24
 Санкт-Петербург (812)309-46-40
 Саратов (845)249-38-78
 Севастополь (8692)22-31-93
 Симферополь (3652)67-13-56
 Смоленск (4812)29-41-54
 Сочи (862)225-72-31
 Ставрополь (8652)20-65-13
 Сыктывкар (8212)25-95-17
 Сургут (3462)77-98-35
 Тамбов (4752)50-40-97
 Тверь (4822)63-31-35

Тольяти (8482)63-91-07
 Томск (3822)98-41-53
 Тула (4872)33-79-87
 Тюмень (3452)66-21-18
 Улан-Удэ (3012)59-97-51
 Ульяновск (8422)24-23-59
 Уфа (347)229-48-12
 Хабаровск (4212)92-98-04
 Чебоксары (8352)28-53-07
 Челябинск (351)202-03-61
 Череповец (8202)49-02-64
 Чита (3022)38-34-83
 Якутск (4112)23-90-97
 Ярославль (4852)69-52-93

Киргизия (996)312-96-26-47

Россия (495)268-04-70

Казахстан (772)734-952-31